

Weather - Proof Day and Night Camera



WDB-5603FDN / WDB-5605FDN

MAIN FEATURES

- EX - CLEAR VIEW UP TO 100 FEET AT TOTAL DARKNESS
- COLOR PICTURE EVEN AT NIGHT
- BEST QUALITY IMAGE / HIGH RESOLUTION 480 TV LINES
- 50 IR-LED LIGHT
- WEATHER PROOF
- EXTREMELY LOW POWER CONSUMPTION
- INSTALLED CDS SENSOR
- LUXURY BODY CASE DESIGN
- EXTREMELY 0 LUX CONDITION
- AUTOMATIC LUX SENSING AT NIGHT

WELDEX CAN CUSTOMIZE CAMERA FOR YOUR SPECIFIC NEED!!

WDB-5603FDN / WDB-5605FDN (Weather - Proof Day and Night Camera)

DIMENSION

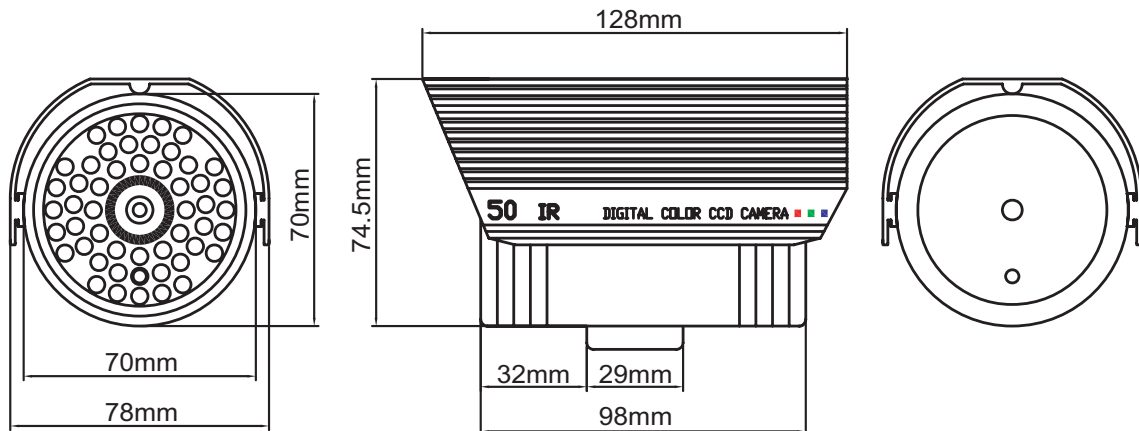

SPECIFICATIONS

MODEL	WDB-5603FDN	WDB-5605FDN
Image Sensor	1/3 Inch SONY CCD Sensor	1/3 Inch SONY SUPER HAD CCD Sensor
Effective Pixels	NTSC:512(H)×492(V) / PAL:512(H)×582(V)	NTSC:768(H)×494(V) / PAL:752(H)×582(V)
Sync System	Internal Sync	
S/N Ratio	More Than 48dB	
Resolution	420 TV lines	480 TV lines
Video Output	1.0Vp-p (75 ohm , composite)	
Illumination	0 Lux (F=1.2)	
BLC/AGC/FL	Built in	
LED	IR LED 50 PCS	
Gamma Characteristics	0.45	
Electronic Shutter Speed	NTSC:1/60~1/10,000 Sec. / PAL:1/50~1/10,000 Sec.	
Power supply	DC 12V / 1A	DC 12V / 500mA
Power consumption	LED ON : 740mA LED OFF : 100mA	LED ON : 750mA LED OFF : 110mA
Operation Temperature	-10°C ~ 50°C C RH95% Max	
Storage Temperature	-20°C ~ 60°C C RH95% Max	
Dimension	78mm(W) × 74.5mm(H) × 128mm(L)	
Weight	Approx. 500g	

BRACKETS



Basic bracket



Color black



Color silver

< CONCEALED BRACKET FOR STRONG INSTALLATION AND WATER-PROOF >